

TR Series — TO-220 and TO-247 Style Power Resistors

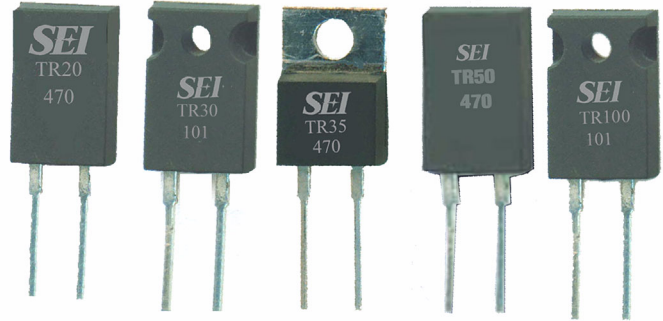

Features

- TR20/30/35/50 comes in TO-220 style power package
- TR100 available in TO-247 style power package
- TR30/35/100 has single screw mounting to heat sink
- Molded case for environmental protection
- Electrically isolated case
- Non-inductive package



Electrical Specifications

Type / Code	Power Rating (Watts) @ 25°C with Heat Sink	Package Style	Maximum Working Voltage*	Resistance Temperature Coefficient	Ohmic Range and Tolerance			
					0.5%	1%	5%	10%
TR 20	20W	TO-220	350V	±50ppm/°C ±100ppm/°C ±200ppm/°C -	11Ω – 10KΩ	11Ω – 10KΩ	11Ω – 10KΩ	11Ω – 10KΩ
TR 30	30W	TO-220			11Ω – 10KΩ	5Ω – 10KΩ	5Ω – 10KΩ	5Ω – 10KΩ
TR 35	35W	TO-220			11Ω – 10KΩ	1.1Ω – 10KΩ	1.1Ω – 10KΩ	1.1Ω – 10KΩ
TR 50	50W	TO-220			-	0.05Ω – 1.0Ω**	0.05Ω – 1.0Ω**	0.05Ω – 1.0Ω**
TR 100	100W	TO-247	350V	±50ppm/°C ±100ppm/°C -	-	10Ω – 10KΩ 3.1Ω – 10KΩ 1Ω – 3Ω**	10Ω – 10KΩ 3.1Ω – 10KΩ 1Ω – 3Ω**	10Ω – 10KΩ 3.1Ω – 10KΩ 1Ω – 3Ω**

* Lesser of \sqrt{PR} or maximum working voltage

** Unspecified TCR; Contact Factory

Environmental Characteristics

Test Item	Specification		Test Method
	TR20/30/35/50	TR100	
Short Time Overload	$\Delta R \pm (0.3\% + 0.001\Omega)$	$\Delta R \pm (0.5\% + 0.001\Omega)$	2 times rated power with applied voltage not to exceed 1.5 times maximum continuous operating voltage for 5 seconds
Load Life	$\Delta R \pm (1.0\% + 0.001\Omega)$	$\Delta R \pm (1.0\% + 0.001\Omega)$	MIL-R-39009, 2000 hours at rated power
Moisture Resistance	$\Delta R \pm (0.5\% + 0.001\Omega)$	$\Delta R \pm (0.5\% + 0.001\Omega)$	MIL-STD-202, Method 103B
Thermal Shock	$\Delta R \pm (0.3\% + 0.001\Omega)$	$\Delta R \pm (0.5\% + 0.001\Omega)$	MIL-STD-202, Method 107G
Terminal Strength	$\Delta R \pm (0.2\% + 0.001\Omega)$	$\Delta R \pm (0.2\% + 0.001\Omega)$	MIL-STD-202, Method 211, Condition A (Pull Test) 2.4N
Vibration, High Frequency	$\Delta R \pm (0.2\% + 0.001\Omega)$	$\Delta R \pm (0.4\% + 0.001\Omega)$	MIL-STD-202, Method 204, Condition D
Dielectric Strength			1800VAC
Insulation Resistance			10GΩ min

Operating Temperature Range : -65°C to +150°C (TR20/30/35/50)

-65°C to +175°C (TR100)

How to Order

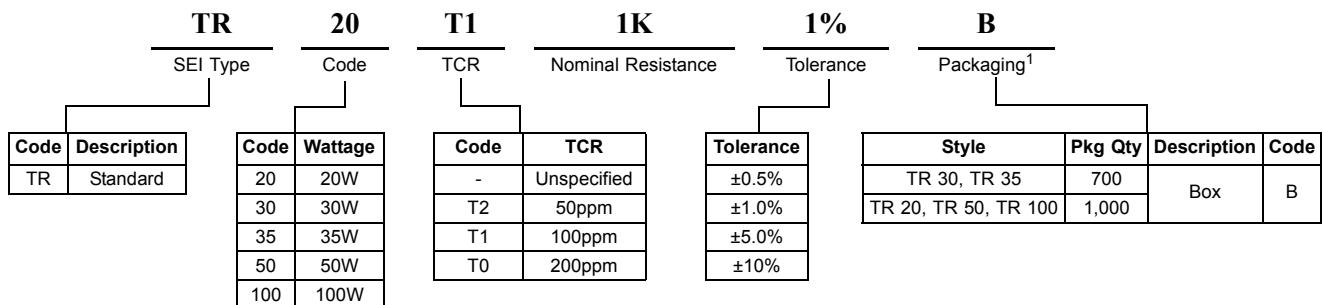

1. Tube Packaging may be available for large volumes. Please contact factory for details.

Mechanical Specifications					inches mm
Type /Code	TR20	TR30	TR35	TR50	TR100
A	0.41 ± 0.01 10.41 ± 0.26	0.41 ± 0.01 10.41 ± 0.26	0.40 ± 0.01 10.16 ± 0.25	0.41 ± 0.01 10.41 ± 0.26	0.62 ± 0.01 15.75 ± 0.26
B	0.64 ± 0.01 16.26 ± 0.26	0.64 ± 0.01 16.26 ± 0.26	0.58 ± 0.01 14.75 ± 0.25	0.64 ± 0.01 16.26 ± 0.26	0.815 ± 0.01 20.7 ± 0.26
C	0.125 ± 0.01 3.18 ± 0.26	0.125 ± 0.01 3.18 ± 0.26	0.17 ± 0.015 4.44 ± 0.38	0.125 ± 0.01 3.18 ± 0.26	0.195 ± 0.01 4.95 ± 0.26
D	0.05 ± 0.005 1.27 ± 0.13	0.05 ± 0.005 1.27 ± 0.13	0.05 ± 0.005 1.27 ± 0.13	0.05 ± 0.005 1.27 ± 0.13	0.143 ± 0.007 3.63 ± 0.18
E	0.03 ± 0.004 0.76 ± 0.10	0.03 ± 0.004 0.76 ± 0.10	0.031 ± 0.003 0.78 ± 0.08	0.03 ± 0.004 0.76 ± 0.10	0.06 ± 0.004 1.52 ± 0.10
F	0.20 ± 0.01 5.08 ± 0.26	0.20 ± 0.01 5.08 ± 0.26	0.20 ± 0.01 5.08 ± 0.26	0.20 ± 0.01 5.08 ± 0.26	0.40 ± 0.01 10.16 ± 0.26
G	0.13 ± 0.03 3.30 ± 0.76	0.13 ± 0.03 3.30 ± 0.76	0.13 ± 0.03 3.30 ± 0.76	0.13 ± 0.03 3.30 ± 0.76	0.11 ± 0.03 2.79 ± 0.76
H	0.50 ± 0.05 12.7 ± 1.27	0.50 ± 0.05 12.7 ± 1.27	0.539 ± 0.04 13.7 ± 1.0	0.50 ± 0.05 12.7 ± 1.27	0.57 ± 0.05 14.48 ± 1.27
J	0.019 ± 0.004 0.50 ± 0.10	0.019 ± 0.004 0.50 ± 0.10	0.024 ± 0.003 0.62 ± 0.08	0.019 ± 0.004 0.50 ± 0.10	0.032 ± 0.01 0.81 ± 0.26
K	0.07 ± 0.01 1.78 ± 0.26	0.07 ± 0.01 1.78 ± 0.26	0.09 ± 0.01 2.28 ± 0.25	0.07 ± 0.01 1.78 ± 0.26	0.095 ± 0.01 2.41 ± 0.26
M	-	0.125 ± 0.004 3.18 ± 0.1	0.144 ± 0.004 3.65 ± 0.10	-	0.143 ± 0.004 3.63 ± 0.10
N	-	0.125 ± 0.01 3.18 ± 0.26	0.116 ± 0.004 2.95 ± 0.10	-	0.21 ± 0.01 5.33 ± 0.26
O	-	-	0.051 ± 0.004 1.30 ± 0.10	-	-
P	-	-	0.24 ± 0.004 6.10 ± 0.10	-	-

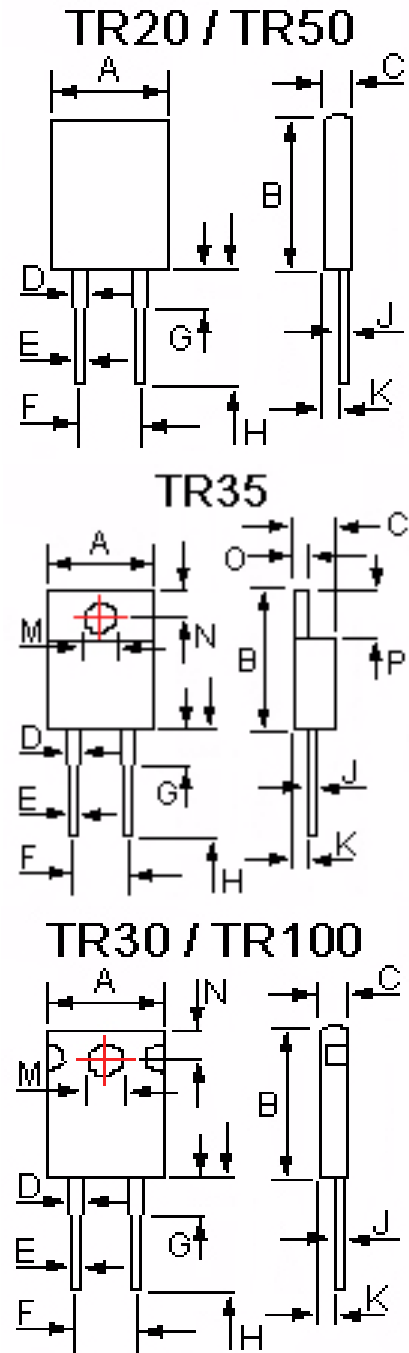

*Mounting Note: When mounting ensure entire ceramic portion of case is mounted on a clean, flat heat sink with an appropriate thermal interface, such as thermal grease. For screw mounting use of a compression washer at a force of 150 to 300lbs (665 to 1330N) is recommended without exceeding mounting torque of 8 in-lbs (0.9 N-m) to avoid package damage. For clip mounting use of a round or smooth clip in contact area is recommended to avoid a concentrated hot spot on package.

Electrical Thermal Characteristics					
	TR20	TR30	TR35	TR50	TR100
Free Air Power Rating	3W in free air at 25°C	2.25W in free air at 25°C	2.5W in free air at 25°C	3W in free air at 25°C	3.5W in free air at 25°C
The case temperature is to be used for the definition of the applied power limit					
The case temperature measurement must be made with a thermocouple contacting the center of the component mounted on the designed heat sink					
TR50/100 must be mounted to head sink using proper mounting clip for efficient heat dissipation					